



F4E 030-040 Series Spin-On Filter Assemblies

For Hydraulic and Lube Oil Applications



Features

- Operating pressure 200 psi (14 bar)
- Element collapse rating of 75 psid (5 bar)
- Static burst pressure 400 psi (28 bar)
- 30 & 40 gpm (114 & 151 lpm) nominal flow rates
- Elements available with cellulose and water removal media
- NPT or SAE straight thread ports
- Optional visual indicator
- Interchangeable with competitive spin-ons



Technical Data

- Pressure & Temperature Rating
 - Operating Pressure: 200 psi (14 bar)
 - Burst Pressure: 400 psi (28 bar)
 - Operating Temperature: -40°F to +250°F (-40°C to +121°C)
- Materials of Construction
 - Head: Aluminum Alloy
 - Spin-on Can: Steel
- Bypass Valve
 - Bypass Valve Setting: 3 psid (0.2 bar) ±10%
25 psid (1.2 bar) ±10%
No bypass
- Differential Pressure Indicators
 - Visual Indicator: 18 psid (1.2 bar) ±10% activation, manual reset
- Seal Material Options
 - Seal Material: Buna
Viton®

Elements

PTI filter elements are manufactured with the highest quality materials. PTI filter elements feature multi-layer construction for increased dirt-holding capacity and low pressure drop. PTI elements provide cost-effective contamination control for the most demanding applications. All elements are tested to the latest industry standards including ISO 16889 procedure for multipass efficiency.

Filtration Rating

Code	Micron Rating	Media
B	3 µm	Cellulose
C	10 µm	Cellulose
D	25 µm	Cellulose
E	10 µm	Water Removal
F	25 µm	Water Removal

Flow Rate/Pressure Drop Curves

Housing F4E 030/040 - Flow vs Pressure Drop

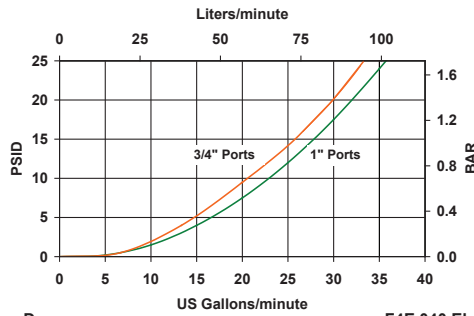

F4E 030 Elements - Flow vs Pressure Drop

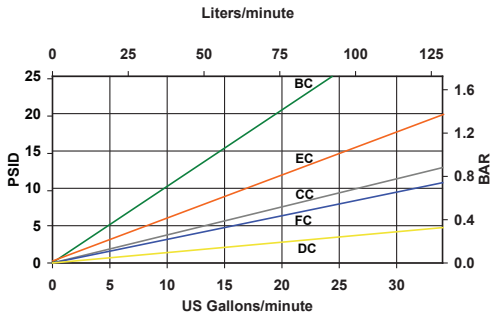

F4E 040 Elements - Flow vs Pressure Drop

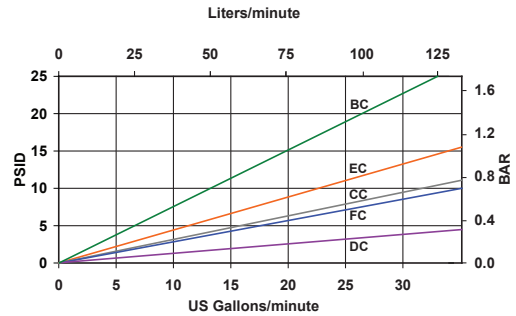

Pressure drop curves are based on 150 SUS (32 cSt) petroleum base hydraulic fluid of 0.9 S.G.
 Filter Assembly ΔP = Housing ΔP + Element ΔP

Assembly Dimensions in Inches (mm)

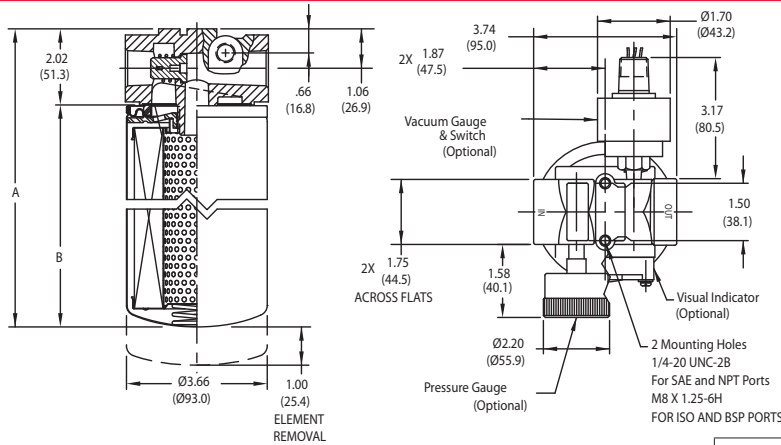

Nominal Flow	-030	-040
Dimension A	7.3 (185)	10.5 (268)
Dimension B	5.3 (135)	8.6 (218)

Filter Assembly (Housing & Element) Weight

Size	030	040
Weight	1.75 lbs (0.80 kg)	1.95 lbs (0.88 kg)

Element Dimensions in Inches (mm)

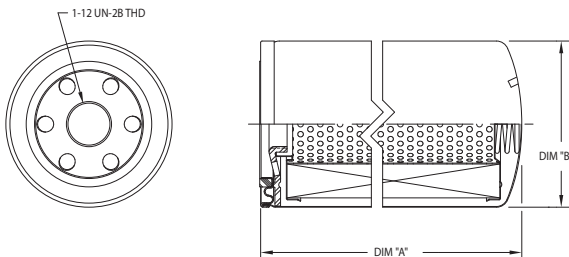

Nominal Flow	-030	-040
Dimension A	5.3 (135)	8.6 (218))
Dimension B	3.7 (93)	3.7 (93)

Ordering Information

Assembly:

F4E	XXX	-	X	X	-	X	X	X	X	X
TBL 1	TBL 2	TBL 3	TBL 4	TBL 5	TBL 6	TBL 7	TBL 8	TBL 9		

Table 1 **Size**

Code	Nominal Flow
030	30 gpm (114 lpm)
040	40 gpm (151 lpm)

Table 2 **Filtration Rating**

Code	Micron Rating	Media
B	3 µm	Cellulose
C	10 µm	Cellulose
D	25 µm	Cellulose
E	10 µm	Water Removal
F	25 µm	Water Removal
N	No Filter Element	

Table 3 **Collapse**

Code	Collapse Rating
C	75 psid (5 bar)
N	No Filter Element

Table 4 **Seals**

Code	Material
B	Buna

* Consult factory for additional seal options

Table 5 **Port**

Code	Option
D	3/4" NPT
E	1" NPT (female)
L	3/4" SAE (-12)
M	1" SAE (-16)

* Consult factory for ISO & BSP for port options

Table 6 **Gauge Options**

Code	Option
0	None
2	Vacuum Gauge
3	Vacuum Switch
5	Color Coded Gauge
6	Pressure Switch

Table 7 **Indicators & Ports**

Code	Option
L	Visual 18 psid (1.2 bar) ± 10%
3	4 x 1/8" NPT Ports
N	None

Table 8 **Valve Options**

Code	Option
N	Non-Bypass
F	25 psid (1.7 bar)
R	3 psid (0.2 bar)

Table 9 **Visual Ind.**

Code	Option
* R	Right Side
* L	Left Side
N	None

* when looking at inlet port

Indicator located on Right side when looking at inlet port

Element:

F4E	-	XXX	-	X	C	-	B
TBL 1		TBL 2	TBL 3		TBL 4		

Table 1 **Size**

Code	Nominal Flow
030	30 gpm (114 lpm)
040	40 gpm (151 lpm)

Table 2 **Filtration Rating**

Code	Micron Rating	Media
B	3 µm	Cellulose
C	10 µm	Cellulose
D	25 µm	Cellulose
E	10 µm	Water Removal
F	25 µm	Water Removal

Table 3 **Collapse**

Code	Collapse Rating
C	75 psid (5 bar)

Table 4 **Seals**

Code	Material
B	Buna

For more info email: fluidpower@ptitechnologies.com



PTI Technologies Inc.
501 Del Norte Boulevard
Oxnard, California 93030
800-331-2701 • 805-604-3700
www.ptitechnologies.com



©2021 An ESCO Technologies Company All Rights Reserved.

PTI Technologies Inc is certified to ISO standards